

# PORTES ROADOR

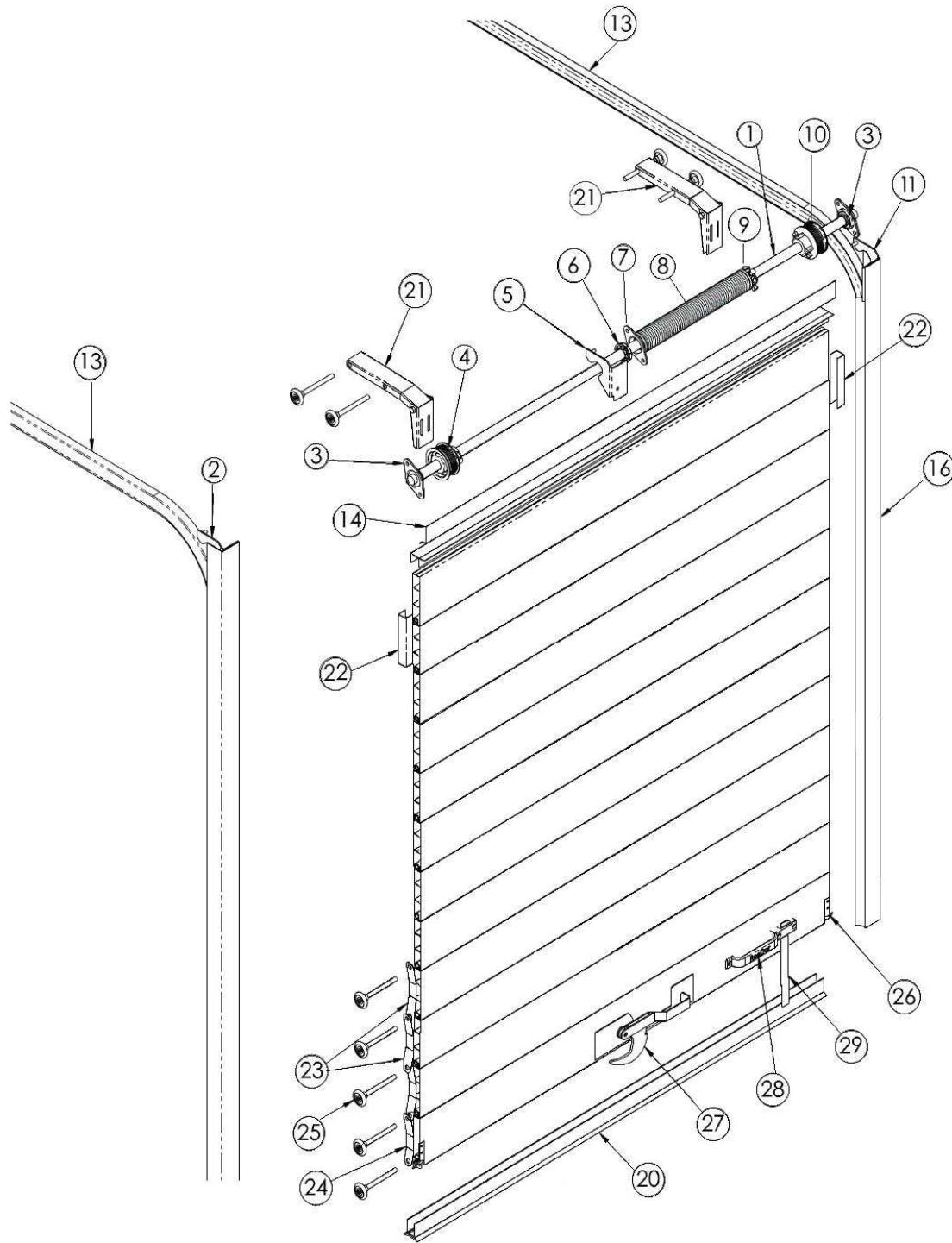

POUR LES CÂBLES & PANNEAUX VOIR PAGES CORRESPONDANTES.

NI (non illustré)

|    |            |                             |    |           |                            |    |           |                            |
|----|------------|-----------------------------|----|-----------|----------------------------|----|-----------|----------------------------|
| 1  | 423-5-324G | Moyeu d'acier galvanisé     | 14 | 423-5-322 | Joint du haut, panneau 1"  | 24 | 423-5-330 | Charnière du bas           |
| 2  | 423-5-309  | Support de gauche           |    | 423-5-357 | Joint du haut, panneau 2"  | 25 | 423-5-302 | Roulette 2", tige inox.    |
| 3  | 423-3-033  | Roulement & Support         | 16 | 423-5-336 | Rail vertical droit        | 26 | 423-5-311 | Support de câble gauche 1" |
| 4  | 423-5-307  | Tambour gauche              |    | 423-5-335 | Rail vertical gauche       |    | 423-5-329 | Support de câble droit 1"  |
| 5  | 423-5-326  | Support centre              | NI | 423-5-345 | Rail vertical gauche 2"    | 27 | 423-5-315 | Loquet, acier inox.        |
| 6  | 423-5-318  | Cale de nylon               | NI | 423-5-346 | Rail vertical droit 2"     | 28 | 423-5-312 | Poignée                    |
| 8  | 423-5-316  | Ressort avec embout         | 19 | 423-5-328 | Support de câble 2"        | 29 | 423-5-305 | Courroie                   |
|    | 423-5-316G | Ressort galvanisé           | 20 | 423-5-320 | Joint du bas, panneau 1"   | NI | 423-5-319 | Embout scellant 1"         |
| 10 | 423-5-306  | Tambour droit               |    | 423-5-356 | Joint du bas, panneau 2"   | NI | 423-5-355 | Embout scellant 2"         |
| 11 | 423-5-308  | Support de droite           | 21 | 423-5-300 | Charnière du haut          | NI | 423-5-321 | Joint de côté              |
| 13 | 423-5-337  | Paire de rails horizontales | 22 | 423-5-327 | Renfort d'acier panneau 6" | NI | 423-5-323 | Joint du haut auxiliaire   |
|    | 423-5-338  | Serrure à 2 points ( int )  | 23 | 423-5-303 | Charnière intermédiaire    | NI | 423-5-340 | Poignée intermédiaire 1"   |
|    |            |                             |    |           |                            | NI | 423-5-348 | Poignée intermédiaire 2"   |

# PORTE RELEVABLE

TODCO

LE NUMÉRO DE SÉRIE DE LA PORTE EST INDIQUÉ SUR LA FACE SUPÉRIEURE DU PANNEAU DU HAUT

RAIL HORIZONTAL  
423-3-195 DROITE 1"  
423-3-194 GAUCHE 1"

423-3-191 JOINT CÔTÉ

RAIL VERTICAL  
423-3-193 GAUCHE  
423-3-192 DROITE

423-3-024 CÂBLE 110"  
423-3-026 CÂBLE 130"

423-3-030 COSSE DOUBLE POUR CÂBLE  
423-3-032 GOUPILLE  
423-3-031 RETENEUR DE CÂBLE  
423-3-004 POIGNÉE  
423-3-045 COURROIE 36"  
423-3-071 GÂCHE  
423-3-070 POIGNÉE  
423-3-072 BOÎTE DE RETENUE

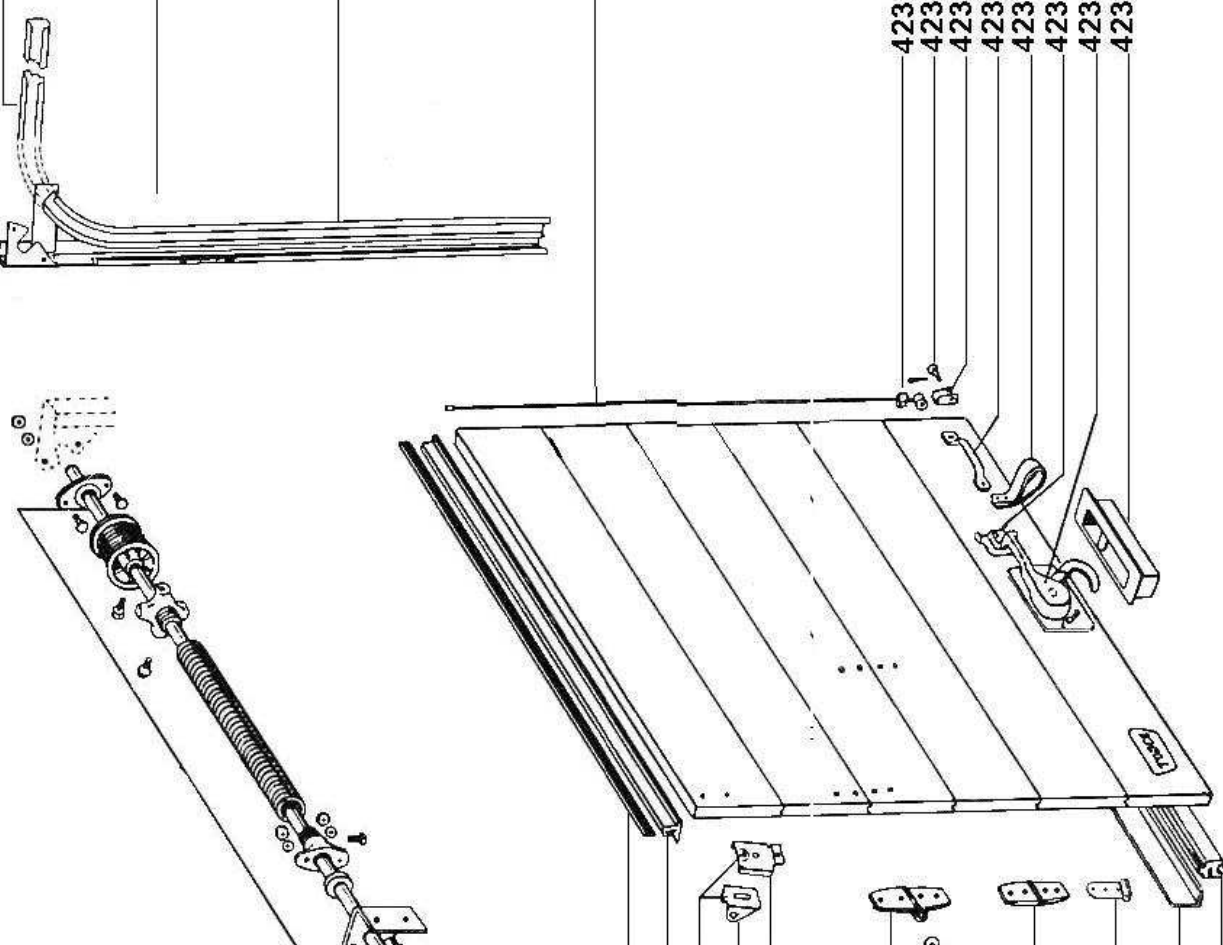

BALANCIER ASSEMBLÉ 423-3-188

TAMBOUR  
GAUCHE 423-3-041  
DROIT 423-3-042

ROULEMENT/SUPPORT 423-3-033  
ROULEMENT SEUL 423-3-043  
ENS. JOINT & RETENEUR 423-3-115

RETENEUR DU HAUT 423-3-183  
JOINT DU HAUT 423-3-182  
CHARNIÈRE ASSEMBLÉE 423-3-010

CHARNIÈRE 423-3-088  
GLISSIÈRE 423-3-089

CHARNIÈRE DU BOUT 423-3-086  
RONDELLE 423-3-009  
ROULETTE 1" 423-3-090

CHARNIÈRE CENTRALE 423-3-087

CHARNIÈRE DU BAS 423-3-114

RETENEUR DU BAS 423-3-179

JOINT DU BAS 423-3-180

# PORTE RELEVABLE

## WHITING

LE NUMÉRO DE SÉRIE DE LA PORTE EST INDIQUÉ SUR LA FACE INTÉRIEURE DU PANNEAU DU HAUT

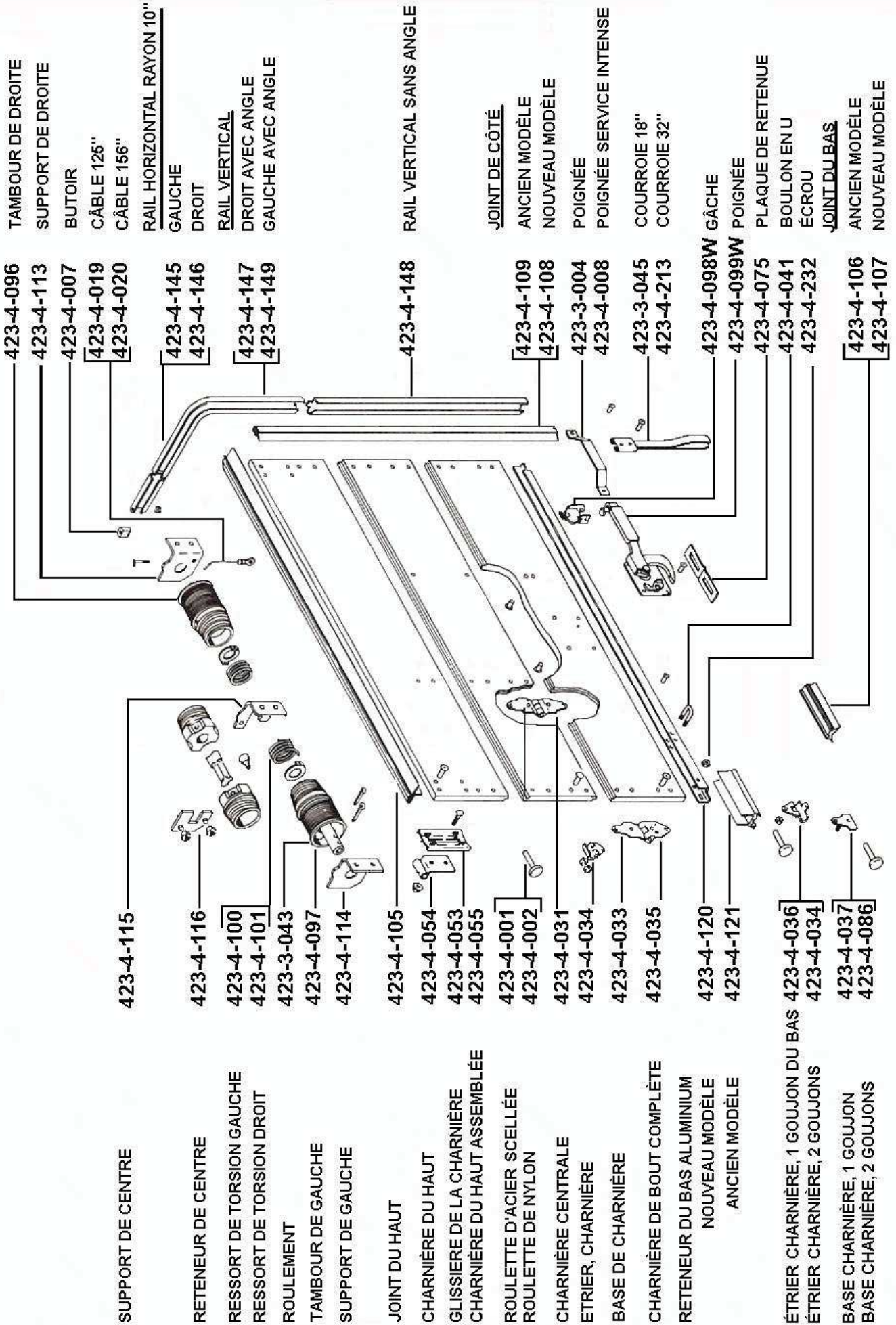

# PORTE RELEVABLE

## WHITING - TEMPGUARD 1 1/2"

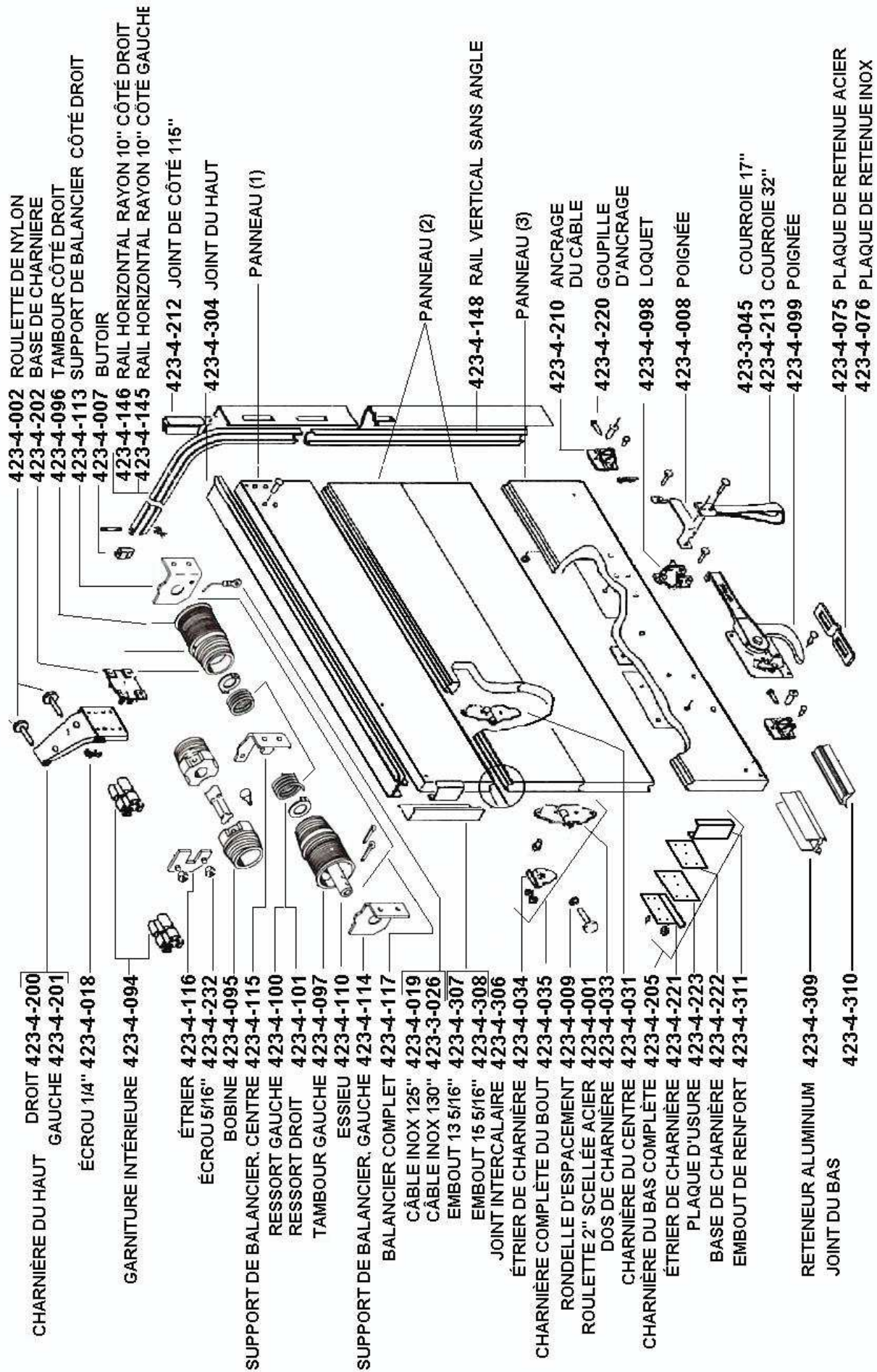

# PORTE RELEVABLE

## WHITING - COLDSAVER 2 1/8"

LE NUMÉRO DE SÉRIE DE LA PORTE EST INDICUÉ SUR LA FACE INTÉRIEURE DU PANNEAU DU HAUT

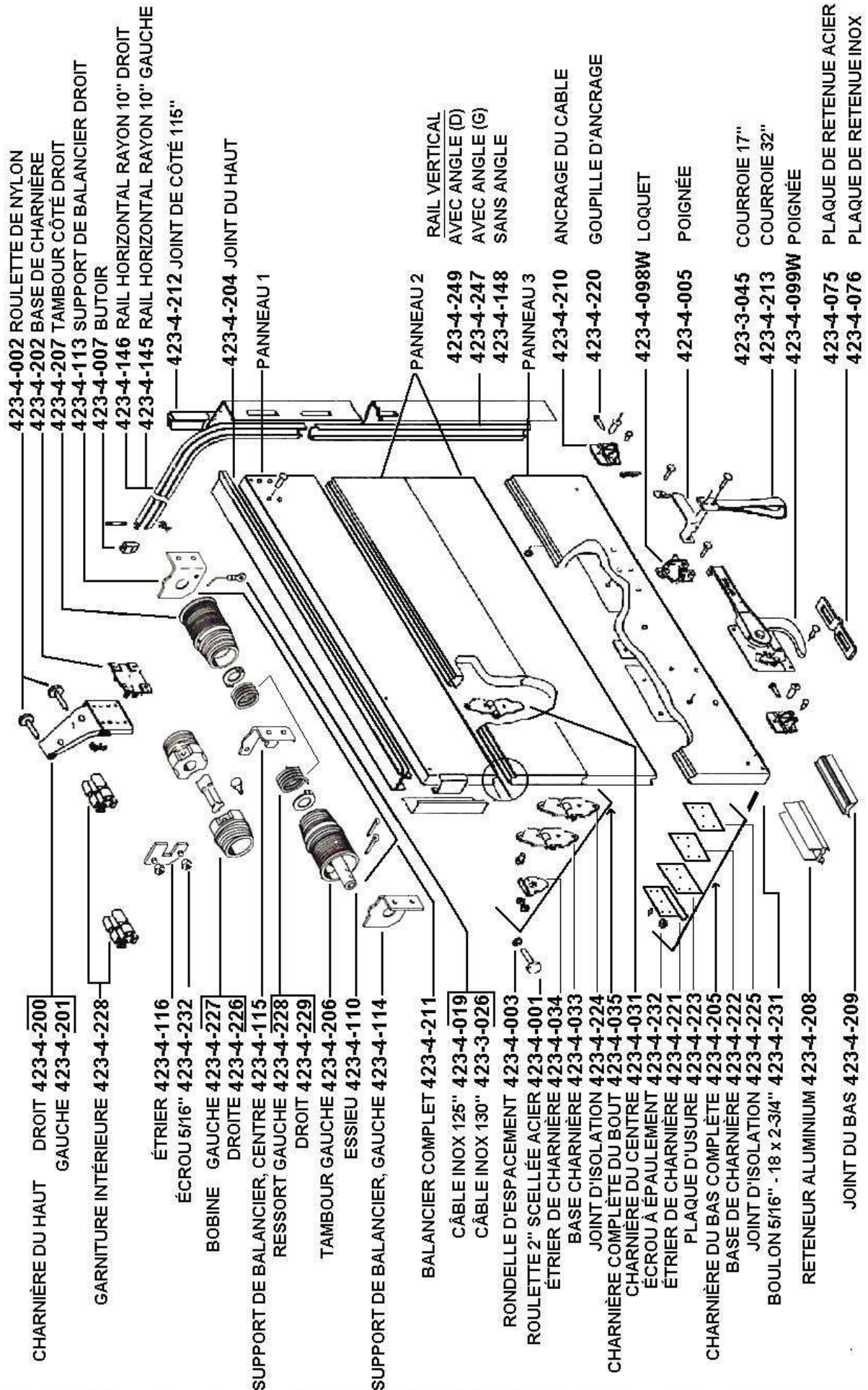

ENSEMBLE RAILS HORIZONTAUX ET VERTICAUX 423-4-237 POUR QUINCAILLERIE INOX.  
AJOUTER SUFFIXE SS AU NUMÉRO DE PIÈCE.

# PORTE RELEVABLE

## PANNEAU DU HAUT NON-ISOLE 3/4"

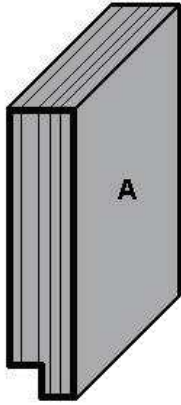

MARCHE D'ESCALIER

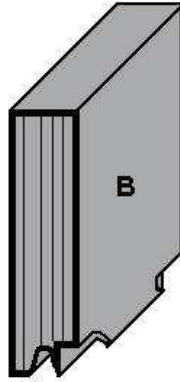

RAINURÉ FEMELLE  
POUR  
CHARNIÈRE ENCASTRÉE

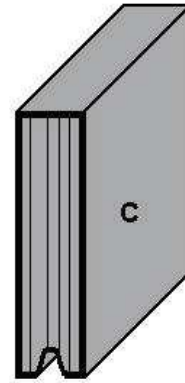

RAINURÉ MÂLE

|            | TYPE | DIMENSIONS    | FINI EXTÉRIEUR  | FINI INTÉRIEUR  |                           |
|------------|------|---------------|-----------------|-----------------|---------------------------|
| 423-4-138  | A    | 15-1/2" X 96" | apprêt blanc    | apprêt blanc    |                           |
| 423-3-174T | B    | 15-1/2" X 96" | apprêt blanc    | apprêt blanc    |                           |
| 423-3-174  | C    | 15-1/2" X 96" | apprêt blanc    | apprêt blanc    |                           |
| 423-3-174A | C    | 15-1/2" X 96" | apprêt blanc    | apprêt blanc    | joint du haut & glissière |
| 423-3-167  | C    | 11-1/2" X 96" | aluminium blanc | apprêt blanc    |                           |
| 423-3-168  | C    | 13-1/2" X 96" | aluminium blanc | apprêt blanc    |                           |
| 423-3-171  | C    | 15-1/2" X 96" | aluminium blanc | apprêt blanc    |                           |
| 423-3-171A | C    | 15-1/2" X 96" | aluminium blanc | apprêt blanc    | joint du haut & glissière |
| 423-4-173  | C    | 15" X 96"     | aluminium blanc | aluminium blanc |                           |
| 423-4-448  | C    | 12" X 96"     | inox.           | apprêt blanc    |                           |
| 423-4-449  | C    | 11-5/8" X 96" | inox.           | apprêt blanc    |                           |
| 423-4-450  | C    | 12-3/8" X 96" | inox.           | apprêt blanc    |                           |

### ROADOR 1"

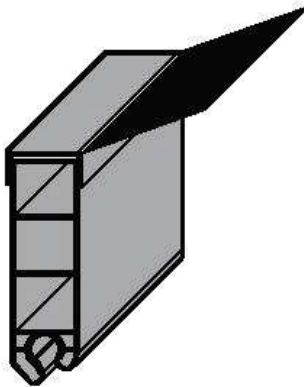

423-5-334

### PARCO

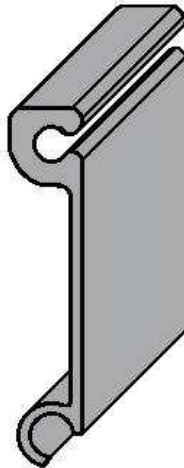

423-5-412

# PORTE RELEVABLE

## PANNEAU INTERMEDIAIRE NON-ISOLE

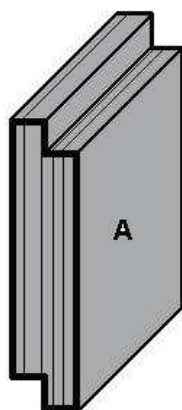

MARCHE D'ESCALIER

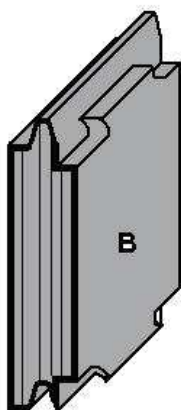

RAINURÉ MÂLE FEMELLE  
POUR CHARNIÈRE ENCASTRÉE

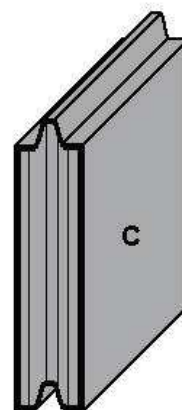

RAINURÉ MÂLE FEMELLE

|            | TYPE | DIMENSIONS    | FINI EXTÉRIEUR  | FINI INTÉRIEUR  |  |
|------------|------|---------------|-----------------|-----------------|--|
| 423-4-134  | A    | 11-1/2" X 96" | apprêt blanc    | apprêt blanc    |  |
| 423-4-135  | A    | 15-1/2" X 96" | apprêt blanc    | apprêt blanc    |  |
| 423-3-169T | B    | 11-1/2" X 96" | apprêt blanc    | apprêt blanc    |  |
| 423-3-170T | B    | 12" X 96"     | apprêt blanc    | apprêt blanc    |  |
| 423-3-172T | B    | 15" X 96"     | apprêt blanc    | apprêt blanc    |  |
| 423-3-173T | B    | 15-1/2" X 96" | apprêt blanc    | apprêt blanc    |  |
| 423-3-169  | C    | 11-1/2" X 96" | apprêt blanc    | apprêt blanc    |  |
| 423-3-170  | C    | 12" X 96"     | apprêt blanc    | apprêt blanc    |  |
| 423-3-172  | C    | 15" X 96"     | apprêt blanc    | aluminium blanc |  |
| 423-3-173  | C    | 15-1/2" X 96" | apprêt blanc    | apprêt blanc    |  |
| 423-4-170  | C    | 11-5/8" X 96" | aluminium blanc | aluminium blanc |  |
| 423-4-171  | C    | 15" X 96"     | aluminium blanc | aluminium blanc |  |
| 423-4-451  | C    | 11-1/2" X 96" | inox.           | apprêt blanc    |  |
| 423-4-452  | C    | 15-1/2" X 96" | inox.           | apprêt blanc    |  |

### ROADOR 1"

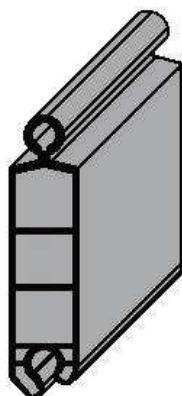

### PARCO

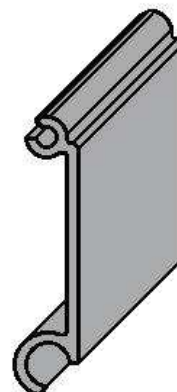

423-5-331

5" de hauteur

423-5-413

2" de hauteur

423-5-332

5" de hauteur avec renfort d'acier

423-5-414

5" de hauteur

# PORTE RELEVABLE

## PANNEAU DU BAS NON-ISOLÉ

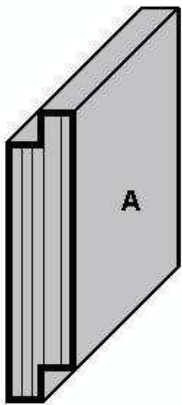

MARCHE D'ESCALIER

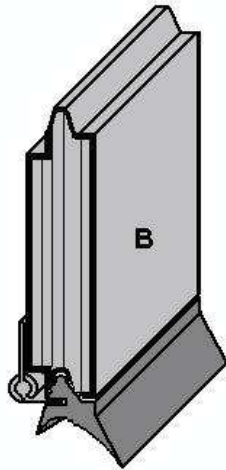

RAINURÉ MÂLE/FEMELLE  
POUR CHARNIÈRE ENCASTRÉE

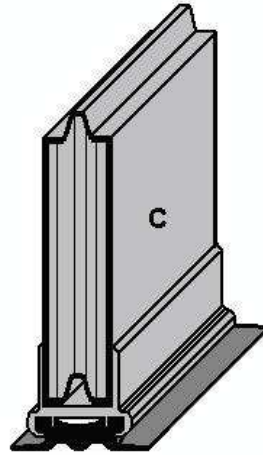

RAINURÉ MÂLE/FEMELLE  
AVANT 1998

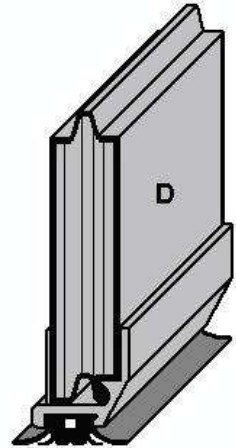

RAINURÉ MÂLE/FEMELLE  
APRÈS 1998

|            | TYPE | DIMENSIONS    | FINI EXTÉRIEUR  | FINI INTÉRIEUR  | NOTES            |
|------------|------|---------------|-----------------|-----------------|------------------|
| 423-4-138  | A    | 15-1/2" X 96" | apprêt blanc    | apprêt blanc    | haut & bas       |
| 423-3-175T | B    | 15-1/2" X 96" | apprêt blanc    | apprêt blanc    |                  |
| 423-3-175  | C    | 15-1/2" X 96" | apprêt blanc    | apprêt blanc    | reteneur & joint |
| 423-3-175W | D    | 15-1/2" X 96" | apprêt blanc    | apprêt blanc    | reteneur & joint |
| 423-3-176  | D    | 15-1/2" X 96" | apprêt blanc    | apprêt blanc    | complet          |
| 423-3-177  | D    | 11-1/2" X 96" | apprêt blanc    | apprêt blanc    |                  |
| 423-3-109  | D    |               | aluminium blanc | apprêt blanc    |                  |
| 423-4-175  | D    | 11-5/8" X 96" | aluminium blanc | aluminium blanc | reteneur & joint |
| 423-4-175S | D    | 11-5/8" X 96" | aluminium blanc | aluminium blanc | complet          |
| 423-4-176  | D    | 18" X 96"     | aluminium blanc | aluminium blanc | reteneur & joint |
| 423-4-455  | D    | 15-1/4" X 96" | inox.           | apprêt blanc    | complet          |

### ROADOR 1"

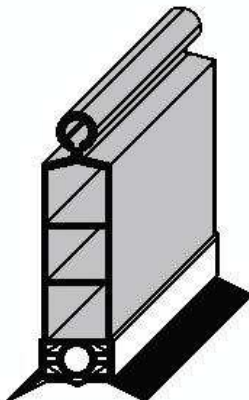

423-5-333 sans poignée  
423-5-359 complet

### PARCO

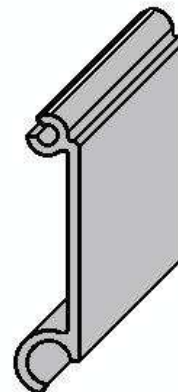

423-5-415



# PORTE RELEVABLE

## PANNEAU DU HAUT - ISOLE

**TODCO POLARGUARD 1-1/8"**

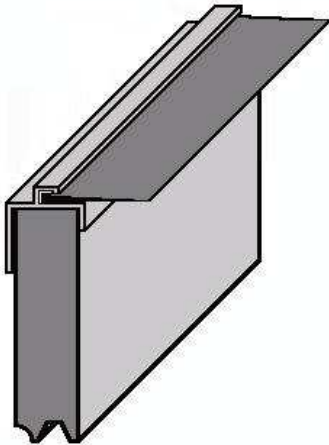

**WHITING TEMPGUARD 1-1/2"**

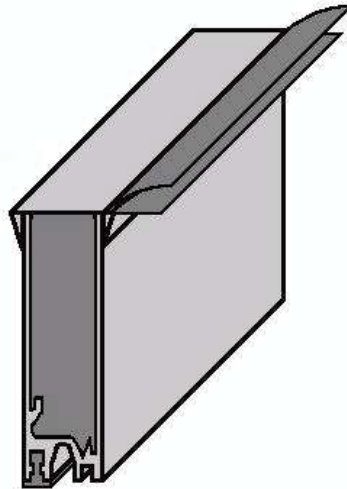

**ROADOR 1"**

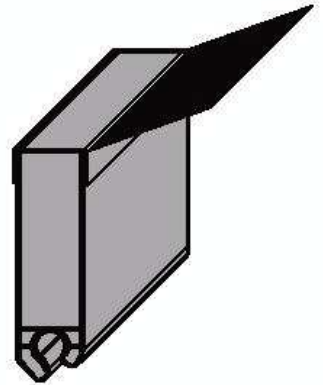

423-3-369 | 11" hauteur

423-3-372 | 15" hauteur

423-4-300 | avec joint seulement

423-5-344 | 5" hauteur

**TODCO POLARGUARD 2-1/2"**

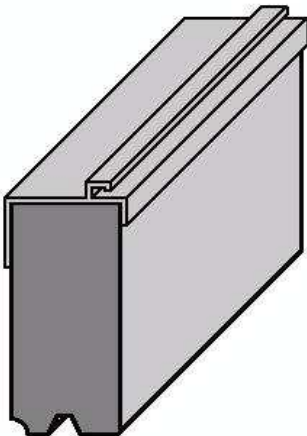

**WHITING COLDSAVER 2-1/8"**

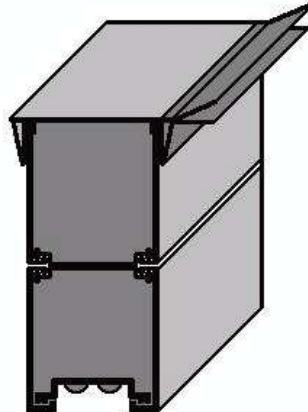

**ROADOR 2"**

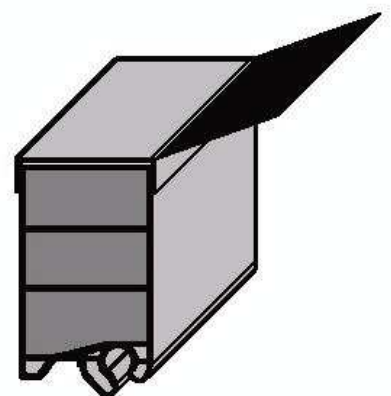

423-3-269 | 12" hauteur

423-3-272 | 15" hauteur

423-4-214 | avec joint charnière

423-4-214A | avec joint seulement

423-5-354 | 5" hauteur

GÉNÉRALEMENT 96" DE LONGUEUR. POUR DIMENSIONS SPÉCIFIQUES DONNER LE NUMÉRO DE SÉRIE DE LA PORTE, INDIQUÉ À L'INTÉRIEUR SUR LE PANNEAU DU HAUT.

# PORTE RELEVABLE

## PANNEAU INTERMÉDIAIRE ISOLÉ

**TODCO POLARGUARD 1-1/8"**

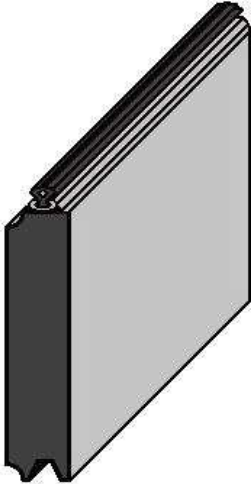

**WHITING TEMPGUARD 1-1/2"**

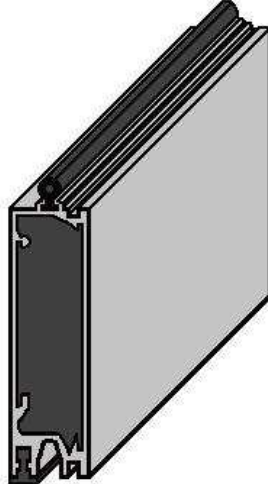

**ROADOR 1"**

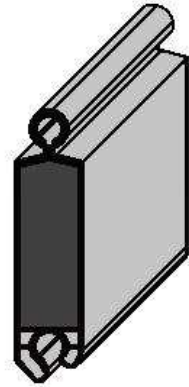

423-3-370 11" hauteur

423-3-373 15" hauteur

423-4-301 15-5/16" hauteur

423-4-302 13-5/16" hauteur

423-5-341 5" hauteur

**TODCO POLARGUARD 2-1/2"**

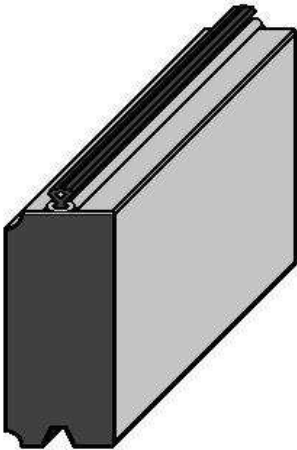

**WHITING COLDSAVER 2-1/8"**

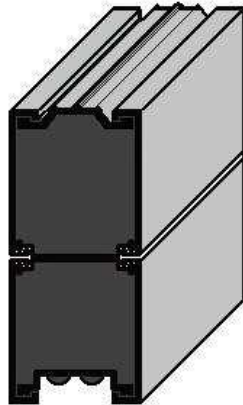

**ROADOR 2"**

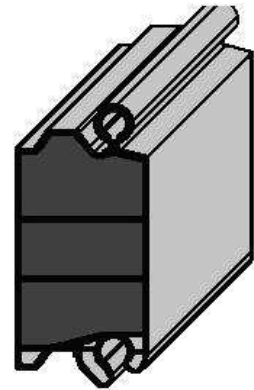

423-3-270 12" hauteur

423-3-273 15" hauteur

423-4-215 12-1/2" hauteur

423-4-216 13-1/2" hauteur

423-4-217 14-1/2" hauteur

423-5-351 5" hauteur

GÉNÉRALEMENT 96" DE LONGUEUR. POUR DIMENSIONS  
SPÉCIFIQUES DONNER LE NUMÉRO DE SÉRIE DE LA PORTE,  
INDIQUÉ À L'INTÉRIEUR SUR LE PANNEAU DU HAUT.

# PORTE RELEVABLE

## PANNEAU DU BAS ISOLÉ

### TODCO POLARGUARD 1-1/8"

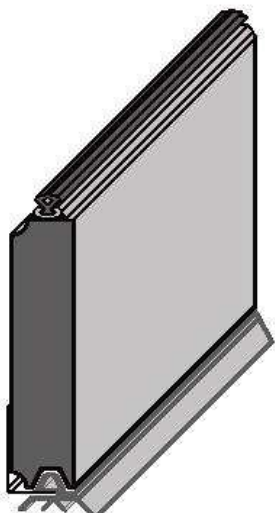

### WHITING TEMPGUARD

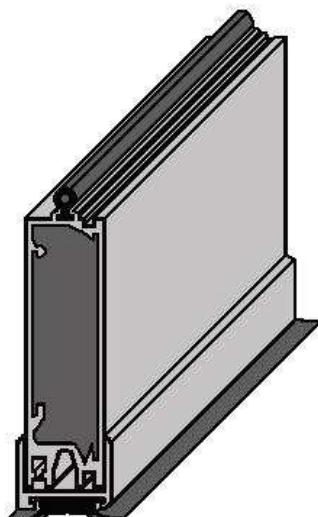

### ROADOR 1"

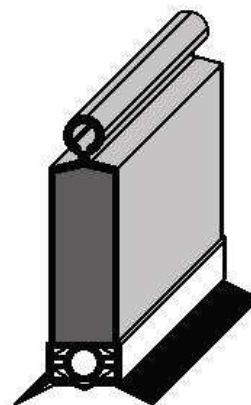

|           |                          |
|-----------|--------------------------|
| 423-3-374 | 11" hauteur sans poignée |
| 423-3-375 | 15" hauteur sans poignée |

|            |          |                                 |
|------------|----------|---------------------------------|
| 423-4-303  | 15-5/16" | complet                         |
| 423-4-303A | 15-5/16" | reteneur & joint                |
| 423-4-303B | 15-5/16" | complet sans poignée            |
| 423-4-303C | 15-5/16" | nu                              |
| 423-4-305  | 13-5/16" | complet                         |
| 423-4-305A | 13-5/16" | reteneur & joint                |
| 423-4-305B | 13-5/16" | complet sans poignée            |
| 423-4-305C | 13-5/16" | nu                              |
| 423-4-315  | 15-5/16" | complet avec poignée intérieure |

|            |   |
|------------|---|
| 423-5-342  | complet   |
| 423-5-342B | sans poignée                                      |
| 423-5-343  | sans poignée pour installation poignée intérieure |

### TODCO POLARGUARD 2-1/2"

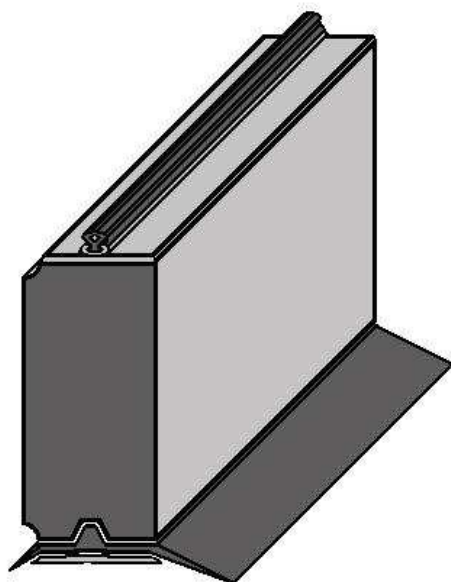

### WHITING COLDSAVER

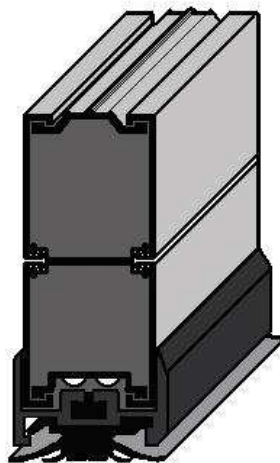

### ROADOR 2"

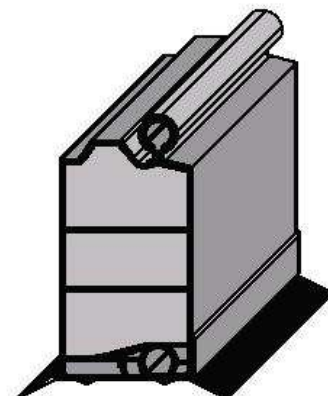

|           |                          |
|-----------|--------------------------|
| 423-3-274 | 12" hauteur sans poignée |
| 423-3-275 | 15" hauteur sans poignée |

|            |         |                      |
|------------|---------|----------------------|
| 423-4-203  | 14-1/2" | complet              |
| 423-4-203A | 14-1/2" | reteneur & joint     |
| 423-4-203B | 14-1/2" | complet sans poignée |
| 423-4-218  | 12-1/2" | complet              |
| 423-4-218A | 12-1/2" | reteneur & joint     |
| 423-4-218B | 12-1/2" | complet sans poignée |
| 423-4-219  | 13-1/2" | complet              |
| 423-4-219A | 13-1/2" | reteneur & joint     |
| 423-4-219B | 13-1/2" | complet sans poignée |

|            |   |
|------------|---|
| 423-5-352  | complet   |
| 423-5-352B | sans poignée                                      |
| 423-5-353  | sans poignée pour installation poignée intérieure |

GÉNÉRALEMENT 96" DE LONGUEUR. POUR DIMENSIONS SPÉCIFIQUES DONNER LE NUMÉRO DE SÉRIE DE LA PORTE, INDIQUÉ À L'INTÉRIEUR SUR LE PANNEAU DU HAUT.

# PORTE RELEVABLE

## JOINTS DU HAUT

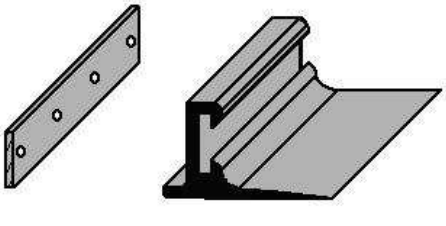
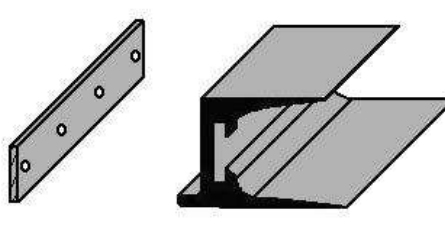
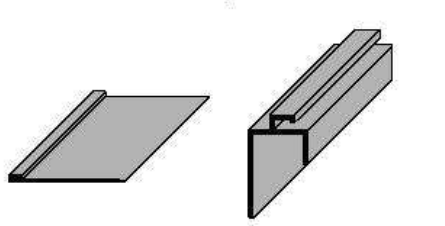
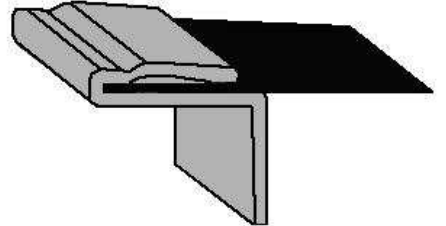
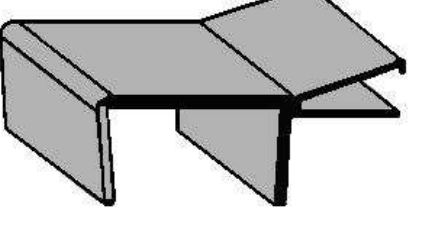
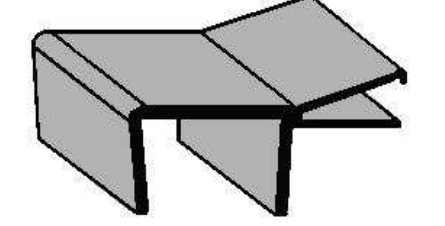
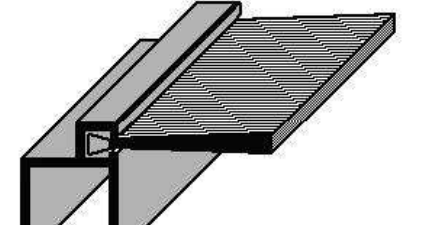
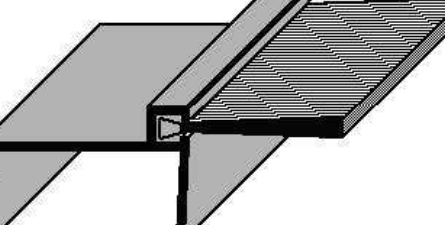
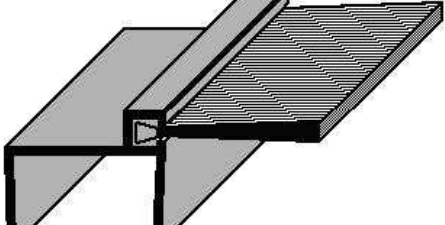
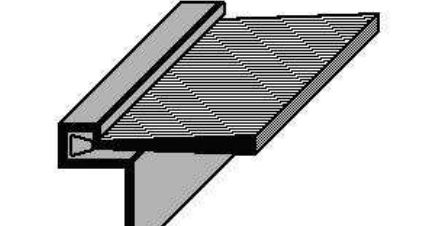
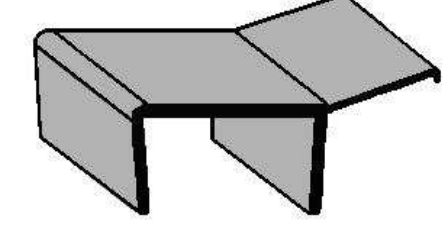
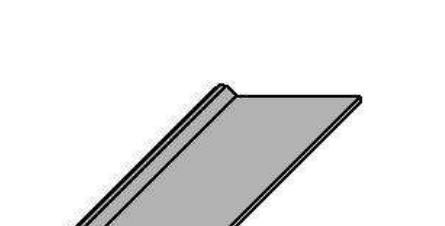
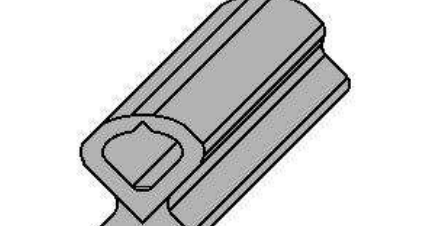
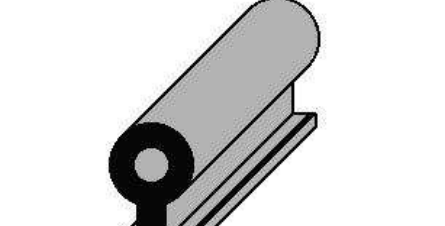
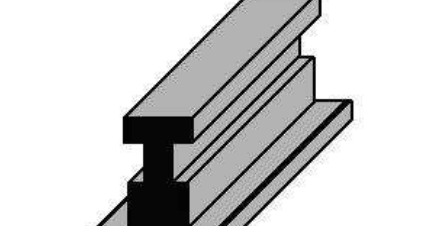
|   |                    |            |   |                    |            |  |                    |            |
|---|--------------------|------------|---|--------------------|------------|--|--------------------|------------|
| <b>TODCO - non isolé</b><br>    |                    |            | <b>TODCO - polar 2-1/2"</b><br>     |                    |            | <b>TODCO - polar 1-1/8"</b><br>     |                    |            |
| 423-3-115   | ENSEMBLE           |            | 423-3-183   | JOINT              | caoutchouc | 423-3-199  | JOINT              | caoutchouc |
| 423-3-182   | JOINT              | caoutchouc | 423-3-186   | RETENEUR           | acier      | 423-3-201  | RETENEUR           | aluminium  |
| 423-3-183   | RETENEUR           | acier      |   |                    |            |  |                    |            |
| <b>WHITING - non isolé</b><br>  |                    |            | <b>WHITING COLDSAVER 2-1/2"</b><br> |                    |            | <b>WHITING TEMPGUARD 1-1/8"</b><br> |                    |            |
| 423-4-105   | caoutchouc         | acier      | 423-4-204   | vinyle             |            | 423-4-304  | vinyle             |            |
| <b>WHITING - non isolé</b><br> |                    |            | <b>WHITING COLDSAVER</b><br>       |                    |            | <b>WHITING TEMPGUARD</b><br>       |                    |            |
| 423-4-158   | ENSEMBLE           |            | 423-4-252   | ENSEMBLE           |            | 423-4-316  | ENSEMBLE           |            |
| 423-4-144   | RETENEUR ALUMINIUM |            | 423-4-253   | RETENEUR ALUMINIUM |            | 423-4-317  | RETENEUR ALUMINIUM |            |
| 423-4-155   | BALAI              |            | 423-4-155   | BALAI              |            | 423-4-155  | BALAI              |            |
| <b>WHITING</b><br>            |                    |            | <b>ROADOR</b><br>                 |                    |            | <b>PARCO</b><br>                  |                    |            |
| 423-4-102   | ENSEMBLE           |            | 423-5-322   | PANNEAU 1"         |            | 423-5-406  | vinyle             |            |
| 423-4-154   | RETENEUR ALUMINIUM |            | 423-5-357   | PANNEAU 2"         |            |  |                    |            |
| 423-4-155   | BALAI              |            |   |                    |            |  |                    |            |
| <b>TODCO - polar</b><br>      |                    |            | <b>WHITING TEMPGUARD</b><br>      |                    |            | <b>WHITING TEMPGUARD</b><br>      |                    |            |
| 423-3-207   | ENTRE LES PANNEAUX |            | 423-4-306   | ENTRE LES PANNEAUX |            | 423-4-318  | ENTRE LES PANNEAUX |            |

# PORTE RELEVABLE

## JOINT DE COTE

TODCO

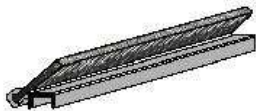

423-3-119

TODCO

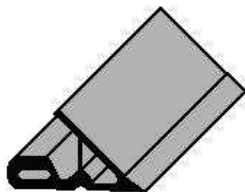

423-3-191

TODCO

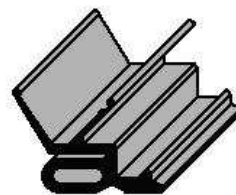

423-3-118

WHITING

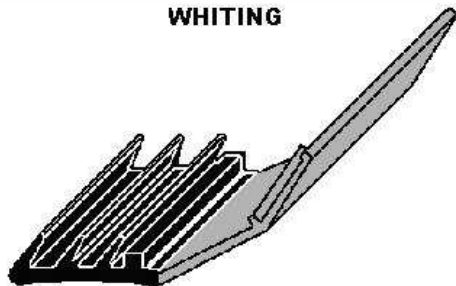

423-4-108 vinyle noir/gris avant 89

WHITING

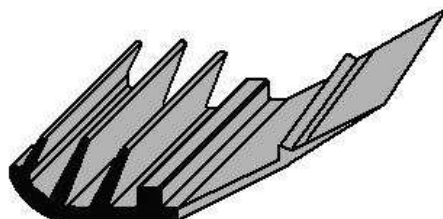

423-4-109 vinyle gris après 89

WHITING

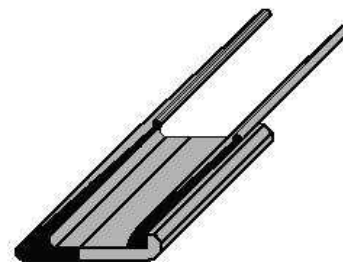

423-4-212 vinyle gris porte isolée

WHITING



423-4-078 aluminium balai

WHITING

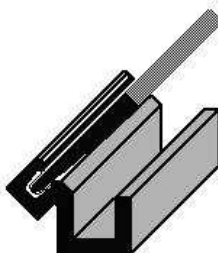

423-4-104 vinyle balai

WHITING

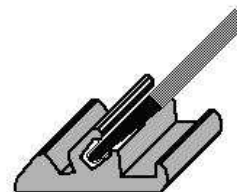

423-4-251 vinyle balai porte isolée

ROADOR

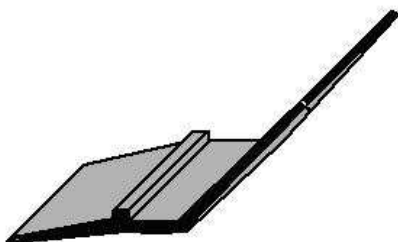

423-5-321 vinyle

# PORTE RELEVABLE

## JOINT DU BAS

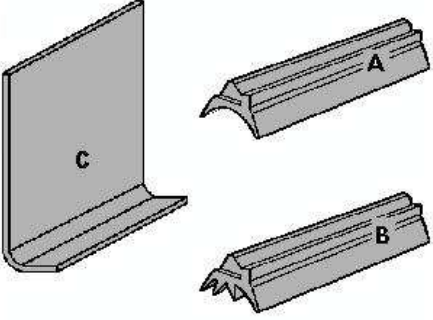
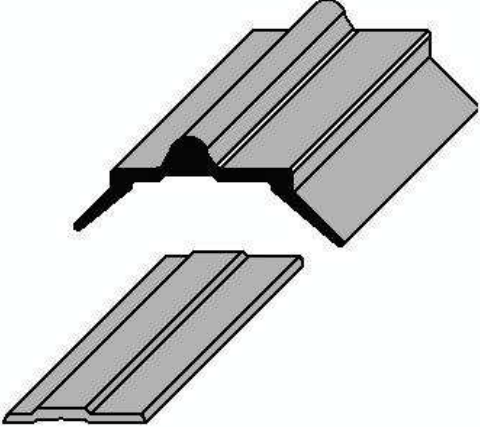
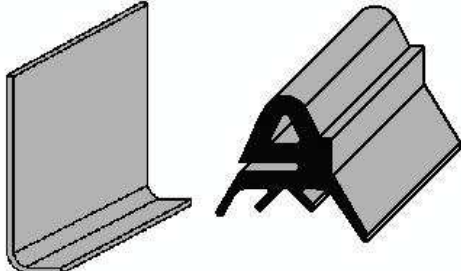
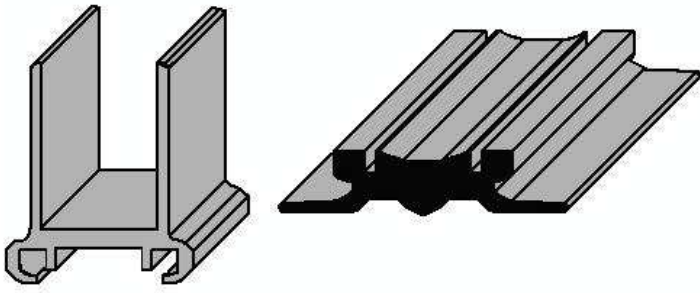
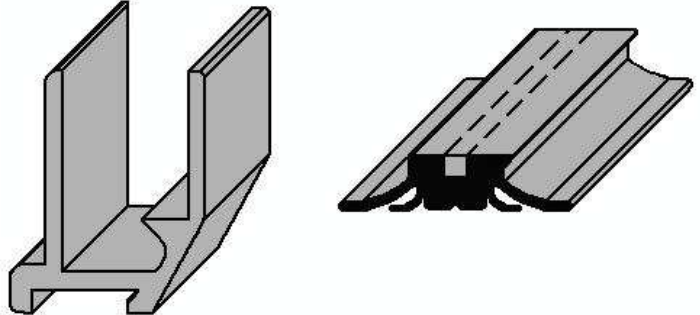
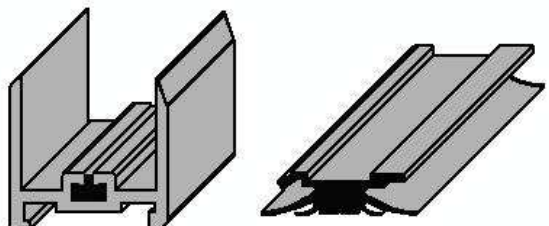
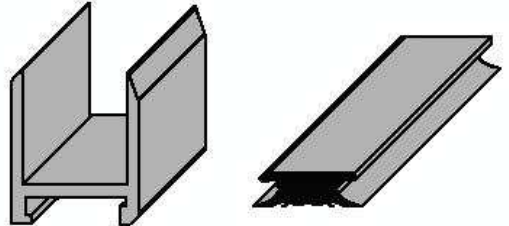
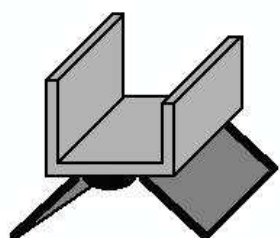
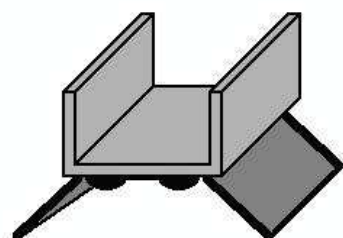
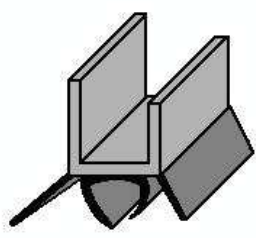
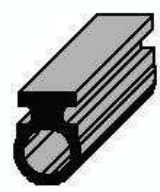
| TODCO - non isolé   |   | TODCO POLAR 2-1/2"   |   | TODCO POLAR 1-1/8"  |                |
|---|---|--|---|---|----------------|
|     |   |    |   |  |                |
| 423-3-180HD   | JOINT   | B  |   |   |                |
| 423-3-180   | JOINT   | A  | 423-3-209   | JOINT   | 423-3-301      |
| 423-3-179   | RETENEUR ACIER  | C  | 423-3-208   | RETENEUR  | 423-3-179      |
|   |   |  |   |   |                |
| WHITING   |   |  | WHITING   |   |                |
|    |   |  |    |   |                |
| 423-4-106   | JOINT   |  | AVANT - 89  | 423-4-107   | JOINT          |
| 423-4-121   | RETENEUR ALUM.  |  |   | 423-4-120   | RETENEUR ALUM. |
|   |   |  |   |   |                |
| WHITING COLDSAVER 2-1/2"  |   |  | WHITING TEMPGUARD 1-1/8"  |   |                |
|  |   |  |   |   |                |
| 423-4-209   | JOINT   |  |   | 423-4-310   | JOINT          |
| 423-4-208   | RETENEUR ALUM.  |  |   | 423-4-309   | RETENEUR ALUM. |
|   |   |  |   |   |                |
| ROADOR  | ROADOR  | COMPOSITE  | PARCO   |   |                |
|   |  |  |  |   |                |
| 423-5-320   | PANNEAU 1"  | 423-5-356  | PANNEAU 2"  | 423-9-107   | PANNEAU 1/2"   |
|   |   |  |   |   | 423-5-407      |

# PORTE RELEVABLE

## BALANCIERS & CÂBLES



| NO. PIÈCES | DIAMÈTRE INTÉRIEUR                              | LONGUEUR RESSORT | TAMBOUR   |                  |
|------------|---|------------------|-----------|------------------|
| 423-3-188  | 1-3/4"  |                  | ALUMINIUM | TODCO NON-ISOLÉE |
| 423-5-317  | SELON DIMENSIONS DE LA PORTE FOURNIR # DE SÉRIE |                  | ALUMINIUM | ROADOR           |

### WHITING

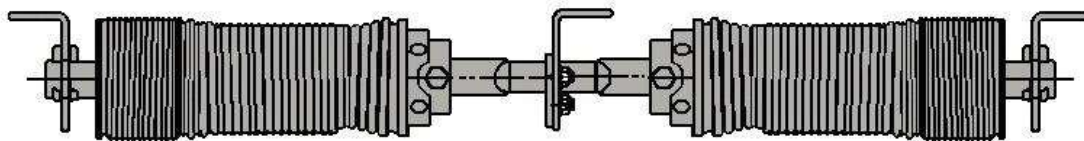

| NO. PIÈCES | DIAMÈTRE INTÉRIEUR | LONGUEUR RESSORT | CODE COULEUR | TAMBOUR   |   |
|------------|--------------------|------------------|--------------|-----------|---|
| 423-4-139A | 2-3/16"            | 14"              |              | PLASTIQUE | CANPAR - PORTE NON-ISOLÉE                                   |
| 423-4-123A | 2-3/16"            | 18"              | ORANGE       | PLASTIQUE | TRANSIT/DYNAMIC   |
| 423-4-118  | 2-3/16"            | 29"              | VERT         | PLASTIQUE | CAMION PORTEUR  |
| 423-4-117W | 2-3/16"            | 31"              | BLANC        | PLASTIQUE | SEMI-REMORQUE   |
| 423-4-159  | 2-3/16"            | 25"              | BLEU         | PLASTIQUE | CAMION PORTEUR - PORTE ISOLÉE                               |
| 423-4-233  | 2-3/16"            | 32"              | MAUVE        | PLASTIQUE | CAMION PORTEUR - PORTE ISOLÉE                               |
| 423-4-234  | 2-3/16"            | 35"              |              | PLASTIQUE | REMORQUE - PORTE ISOLÉE<br>PEUT ETRE REMPLACÉ PAR 423-4-211 |
| 423-4-211  | 2-5/8"             | 31"              | VERT         | ALUMINIUM | REMORQUE - PORTE ISOLÉE                                     |
| 423-4-240  | 2-5/8"             | 34"              |              | ALUMINIUM | REMORQUE - PORTE ISOLÉE INOX.                               |

### CAMION LIVRAISON BREUVAGE

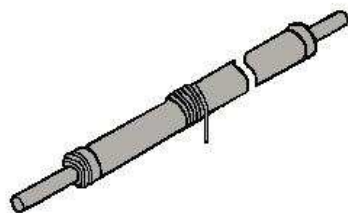

| NO. PIÈCES | OUVERTURE DE PORTE | TAMBOUR |                             |
|------------|--------------------|---------|-----------------------------|
| 423-5-400  | 40"                | SIMPLE  | PARCO-HESSE<br>CABLE INCLUS |
| 423-5-401  | 52"                | SIMPLE  |                             |
| 423-5-402  | 66-5/8"            | SIMPLE  |                             |
| 423-5-403  | 72-5/8"            | DOUBLE  |                             |

### CÂBLES



|           |      |      |                   |
|-----------|------|------|-------------------|
| 423-4-022 | INOX | 97"  |                   |
| 423-3-024 | INOX | 110" | JUSQU'À 100" HAUT |
| 423-3-025 | INOX | 115" | 100" À 105" HAUT  |
| 423-4-019 | INOX | 125" |                   |
| 423-3-026 | INOX | 130" | 105 À 120" HAUT   |

|            |      |      |
|------------|------|------|
| 423-5-310A | INOX | 110" |
| 423-5-310  | INOX | 115" |



# PORTE RELEVABLE

## COMPOSANTE - LOQUET

|            |  |            |  |           |  |
|------------|--|------------|--|-----------|--|
| WHITING    |  | WHITING    |  | WHITING   |  |
|            |  |            |  |           |  |
| 423-4-099  |  | 423-4-098  |  | 423-4-071 |  |
| ACIER NOIR |  | ACIER NOIR |  | LOQUET    |  |

|                                    |  |           |  |              |  |
|------------------------------------|--|-----------|--|--------------|--|
| WHITING                            |  | WHITING   |  | WHITING      |  |
|                                    |  |           |  |              |  |
| 423-4-089                          |  | 423-4-088 |  | 423-4-023    |  |
| ACIER NOIR AVEC POIGNÉE INTÉRIEURE |  |           |  | BLOC SERRURE |  |

|       |  |  |  |  |  |
|-------|--|--|--|--|--|
| TODCO |  |  |  |  |  |
|       |  |  |  |  |  |

|                   |  |           |        |           |  |
|-------------------|--|-----------|--------|-----------|--|
| BARRURE DOUBLE    |  |           |        |           |  |
| TODCO             |  |           | ROADOR |           |  |
|                   |  |           |        |           |  |
| 423-3-070         |  | 423-3-071 |        | 423-5-315 |  |
| ACIER PLAQUÉ ZINC |  |           |        | INOX      |  |



# PORTE RELEVABLE

## CHARNIÈRE DU HAUT

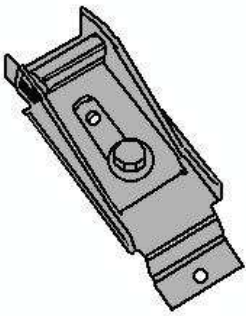
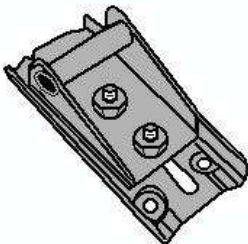
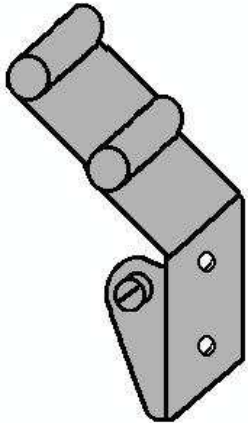
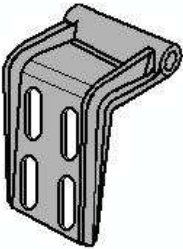
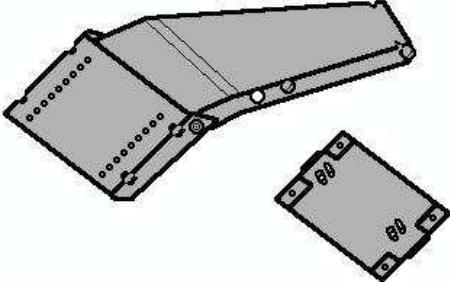
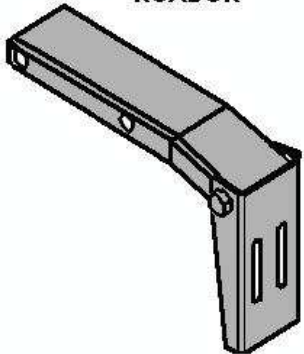
|   |  |   |                  |           |   |           |
|---|--|---|------------------|-----------|---|-----------|
| <b>TODCO POLARGUARD 1-1/8"</b><br>  |  | <b>WHITING</b><br>   |                  |           | <b>WHITING</b><br> |           |
|   |  | ● pour inox. ajouter suffixe SS au numéro   |                  |           |   |           |
|   |  | 423-4-055   | complète         | non isolé |   |           |
|   |  | 423-4-053   | glissière (base) | non isolé |   |           |
| 423-3-010   |  | non isolé   | 423-4-054        | charnière | non isolé   | 423-4-056 |
| <b>TODCO POLARGUARD 2-1/2"</b><br> |  | <b>WHITING</b><br> |                  |           | <b>ROADOR</b><br> |           |
|   |  | 423-4-200   | côté droit       | isolé     |   |           |
|   |  | 423-4-201   | côté gauche      | isolé     |   |           |
| 423-3-204   |  | 423-4-202   | base             | isolé     | 423-5-300   |           |

## ROULETTE

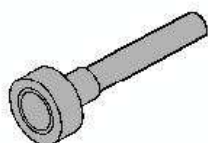

Scellé

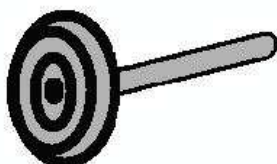

Apparent

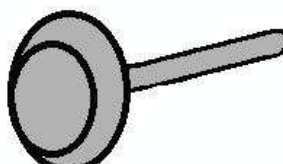

Scellé

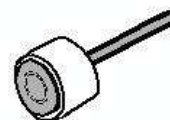

Scellé

|            | ROULETTE           | ROULEMENT | ÉPAULEMENT | TIGE  | FINI | NOTE                               |
|------------|--------------------|-----------|------------|---|------|------------------------------------|
| 423-3-090  | Acier 1"           | Scellé    | 3/8"       | 7/16" dia. 2 1/2" long plaqué                   |      |                                    |
| 423-3-091  | Acier 1"           | Scellé    | 3/8"       | 7/16" dia. 3 1/4" long plaqué                   |      |                                    |
| 423-3-008  | Acier 2"           | Apparent  | 1/4"       | 7/16" dia. 3" long plaqué                       |      |                                    |
| 423-3-008A | Acier 2"           | Apparent  | 1/4"       | 7/16" dia. 3" long chromate de zinc (jaune)     |      |                                    |
| 423-3-112  | Acier 2"           | Apparent  | 1/4"       | 7/16" dia. 5 5/8" long plaqué                   |      |                                    |
| 423-3-112A | Acier 2"           | Apparent  | 1/4"       | 7/16" dia. 5 3/4" long chromate de zinc (jaune) |      |                                    |
| 423-4-001  | Acier 2"           | Scellé    | 1/4"       | 7/16" dia. 2 3/4" long plaqué                   |      | WHITING                            |
| 423-4-002  | Nylon 2"           | Apparent  | 1/4"       | 7/16" dia. 3" long chromate de zinc (jaune)     |      |                                    |
| 423-4-006  | Nylon 2"           | Apparent  | 1/4"       | 7/16" dia. 5 5/8" long plaqué                   |      |                                    |
| 423-5-302  | Nylon 2"           | Scellé    | 1/2"       | 7/16" dia. 4 1/2" long acier inoxydable         |      | ROADOR                             |
| 423-5-410  | Nylon grise 7/8"   | Scellé    | 1/16"      | 3/16" dia. 1 1/4" long acier inoxydable         |      | PARCO-HESSE après 2006             |
| 423-5-416  | Nylon blanche 7/8" | Scellé    | 1/16"      | 3/16" dia. 1 1/4" long galvanisé                |      | PARCO-HESSE de 1994 au 8 juin 2007 |

# PORTE RELEVABLE

## CHARNIÈRES POUR PANNEAUX INTERMÉDIAIRES

### EXTRÉMITÉS

TODCO

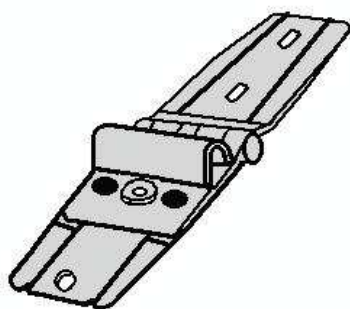

TODCO

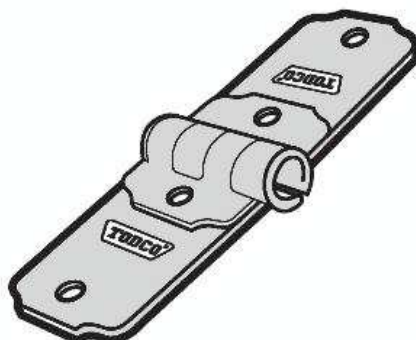

TODCO

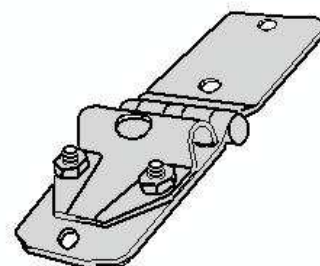

423-3-003 roulettes 2" KENMAR

423-3-086 roulettes 1" panneau encafé

423-3-113 roulettes 1" panneau uni

WHITING

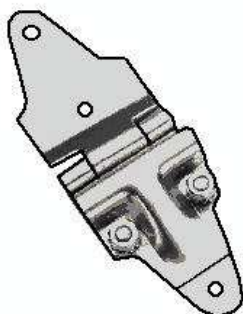

ROADOR

423-4-035 complète inox SS

423-4-033 base inox SS

423-4-034 étrier inox SS

423-5-303 lamelle plastique

### CENTRE

TODCO

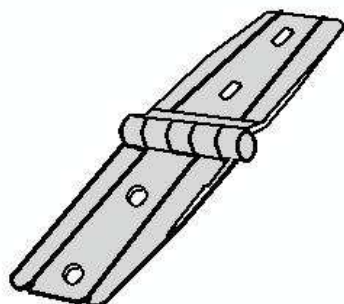

TODCO

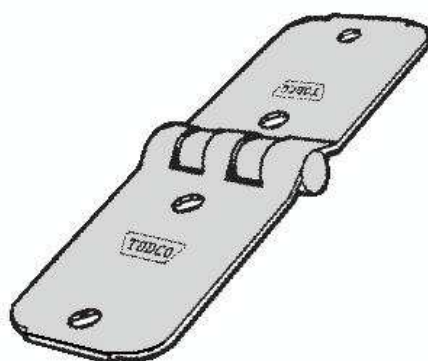

WHITING

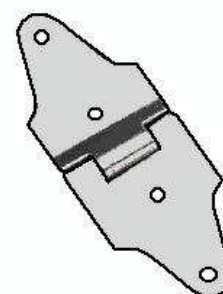





423-3-002 roulettes 2" KENMAR

423-3-087 roulettes 1"

423-4-031 inox SS

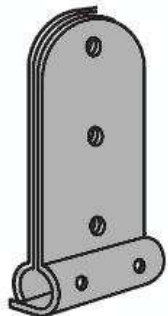
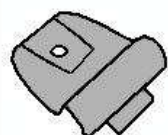
# PORTE RELEVABLE

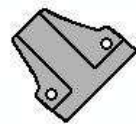
## CHARNIÈRES DU BAS

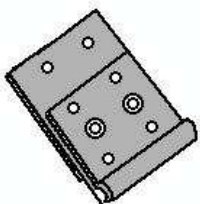
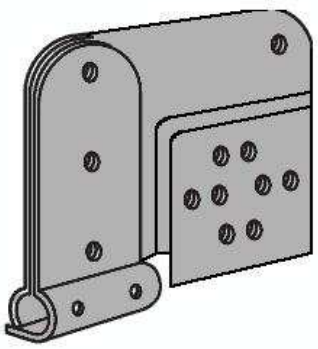
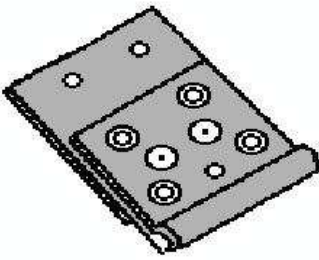
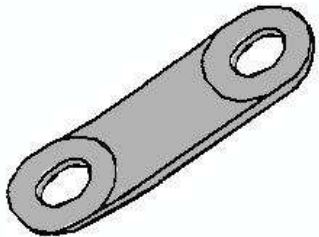
|  |  |  |  |  |  |  |  |  |  |  |  |  |  |  |   |  |  |
|--|--|--|--|--|--|--|--|--|--|--|--|--|--|--|---|--|--|
| <b>TODCO</b><br>  |  |  | <b>WHITING</b><br><br>(1) |  |  | <b>WHITING</b><br><br>(2) |  |  |                     |  |  |  |  |  |  |  |  |
|  |  |  | non isolée   |  |  | inox   |  |  | non isolée   |  |  | inox   |  |  |   |  |  |
| 423-3-114  |  |  | 423-4-036  |  |  | 423-4-037  |  |  | 423-4-034  |  |  | 423-4-086  |  |  | 423-9-036   |  |  |
| non isolée   |  |  | 1  |  |  | 2  |  |  | étrier   |  |  | base   |  |  | service intense   |  |  |
|  |  |  | étrier   |  |  | base   |  |  | 2 goujons  |  |  | 2 goujons  |  |  | 2-1/8" x 4-1/8"   |  |  |
| <b>TODCO</b><br> |  |  | <b>WHITING</b><br>        |  |  |  |  |  | <b>ROADOR</b><br> |  |  |  |  |  |   |  |  |
| 423-3-102L   |  |  | 423-3-102R   |  |  | 423-4-205  |  |  |  |  |  | 423-5-304  |  |  |   |  |  |
| gauche   |  |  | droit  |  |  | isolée   |  |  |  |  |  | lamelle plastique  |  |  |   |  |  |
| isolée   |  |  | isolée   |  |  | 4" x 3-7/8"  |  |  |  |  |  | 6-5/16" long   |  |  |   |  |  |

## SUPPORT D'ANCRAGE POUR CABLE

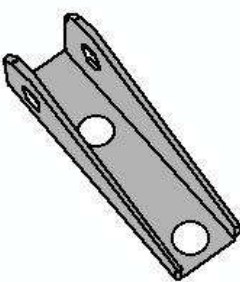
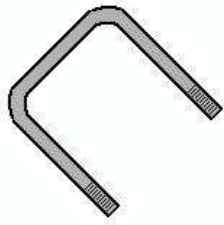
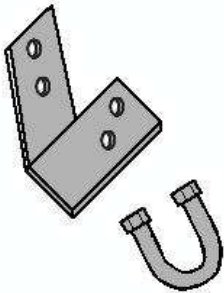
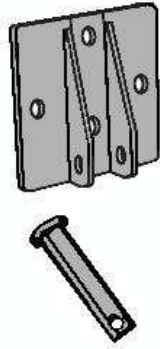
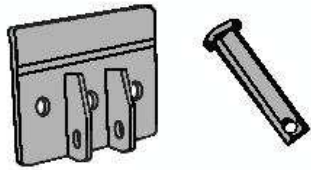
|  |  |  |   |  |  |   |  |  |   |  |  |
|--|--|--|---|--|--|---|--|--|---|--|--|
| <b>TODCO</b><br>  |  |  | <b>WHITING</b><br> |  |  | <b>ROADOR</b><br> |  |  | <b>TODCO</b><br> |  |  |
| 423-3-031  |  |  | 423-4-041   |  |  | 423-5-311   |  |  | 423-3-080   |  |  |
| support  |  |  | support   |  |  | support gauche  |  |  | support   |  |  |
| non isolée   |  |  | non isolée  |  |  | support droit   |  |  | support isolée  |  |  |
| 423-3-032  |  |  | 423-4-232   |  |  | 423-5-329   |  |  | 423-3-032   |  |  |
| goupille   |  |  | écrou   |  |  | boulon en U   |  |  | goupille  |  |  |
| <b>WHITING</b><br> |  |  |   |  |  |   |  |  |   |  |  |
| 423-4-210  |  |  |   |  |  |   |  |  |   |  |  |
| support  |  |  |   |  |  |   |  |  |   |  |  |
| isolée   |  |  |   |  |  |   |  |  |   |  |  |
| 423-4-220  |  |  |   |  |  |   |  |  |   |  |  |
| goupille   |  |  |   |  |  |   |  |  |   |  |  |